

United States of America

United States Patent and Trademark Office

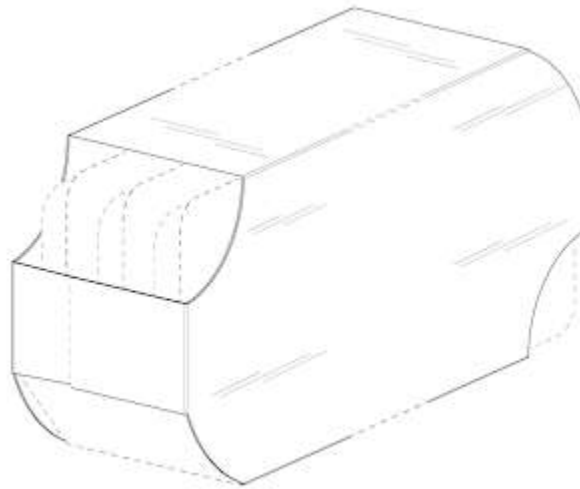

Reg. No. 6,661,693

Registered Mar. 01, 2022

Int. Cl.: 29

Trademark

Supplemental Register

Sargento Foods Inc. (WISCONSIN CORPORATION)
One Persnickety Place
Plymouth, WISCONSIN 53073

CLASS 29: Food package containing cheese; snack food combinations containing primarily cheese and including one or more of the following, namely, crackers, dried fruit and nuts; snack food combination package containing primarily cheese and including one or more of the following, namely, crackers, dried fruit and nuts; snack food containing cheese; cheese-based snack foods; cheese

FIRST USE 2-1-2021; IN COMMERCE 2-1-2021

The mark consists of a three-dimensional configuration of food product packaging with a uniquely shaped opening. The shape of the packaging is depicted in solid lines and is claimed as part of the mark. The broken lines depicting the rectangular shape of the box and the back rectangular opening indicate placement of the mark on the goods and are not part of the mark.

SER. NO. 90-738,117, FILED P.R. 05-27-2021; AM. S.R. 12-29-2021



Dennis H. H. H.

