

# United States of America

## United States Patent and Trademark Office

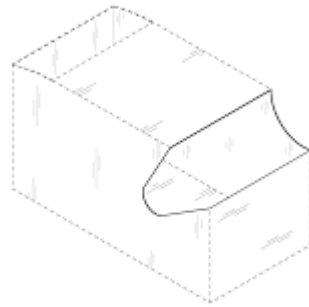

FIG. 1

**Reg. No. 6,258,485**

**Registered Jan. 26, 2021**

**Int. Cl.: 16**

**Trademark**

**Supplemental Register**

Sargento Foods Inc. (WISCONSIN CORPORATION)  
One Persnickety Place  
Plymouth, WISCONSIN 53703

CLASS 16: paper packaging sleeve for food products; paper packaging for food containers

FIRST USE 1-10-2020; IN COMMERCE 1-10-2020

The mark consists of a three-dimensional configuration of food product packaging with a uniquely shaped opening at the top front of the package. The shape of the packaging is depicted in solid lines and is claimed as part of the mark. The broken lines depicting the rectangular shape of the box and the back rectangular opening indicate placement of the mark on the goods and are not part of the mark.

SER. NO. 88-856,377, FILED P.R. 04-01-2020; AM. S.R. 08-05-2020



*Diana H. ...*

Performing the Functions and Duties of the  
Under Secretary of Commerce for Intellectual Property and  
Director of the United States Patent and Trademark Office

